

DPC

DRENA-LINE CLEAN WATER

- Compact dimensions
- Continuous operation
- Integrated float switch
- Manual-automatic switch
- Low level pumping
- Moisture sealed cable inlet



DESCRIPTION

The submersible pumps of the DPC series for clear water are designed for domestic use such as the drainage of infiltrated water, the collection of water from wells, basins or tanks. Check valve and hose connector adaptable for hoses of 3/4 or \varnothing 25-32, included in supply.

Minimum drying level 3 mm.

APPLICATIONS

- Drainage of infiltrated water, lifting of rainwater from grille or well
- Emptying of rooms, tanks and wells

PERFORMANCE

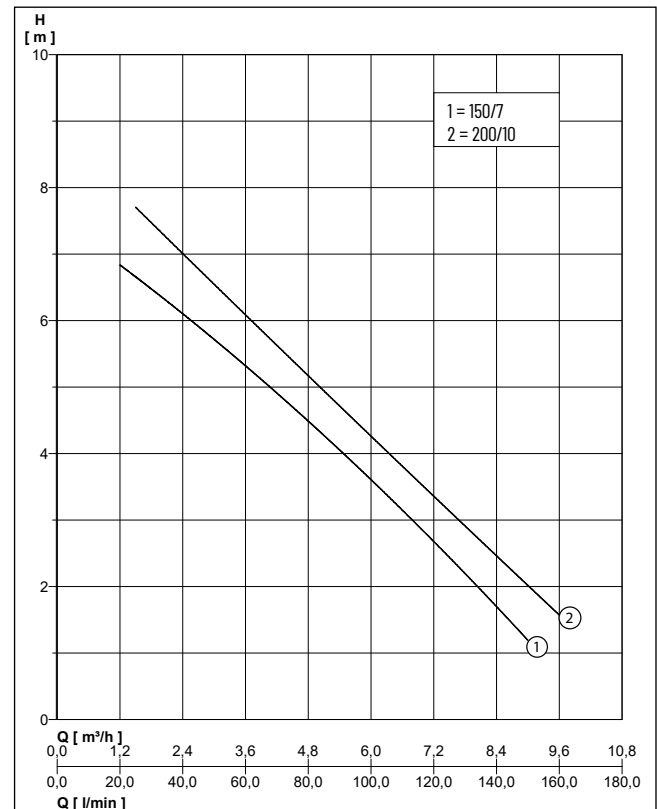

Type	Delivery head H [m]	3	4	5	6	7	8	9
DPC 150/7	Flow rate Q [m³/h]	6.8	5.6	4.0	2.7	0.8		
DPC 200/10		7.7	6.4	4.7	3.5	2.5	1.5	0.7

DPC

DRENA-LINE - CLEAN WATER

MECHANICAL DATA

Free passage	3 mm	Pump housing	Technopolymer
Oil chamber	Yes	Submersible	Yes
Shaft	Stainless steel X 8 CrNi 18-9 (AISI 303)	Counterface	Ceramic. Lubricated in oil chamber
Impeller	Technopolymer	Temperature of the liquid max.	40 °C
Motor housing	Stainless steel X 8 CrNi 18-10 (AISI 304)	Diving depth	7 m
		Weight	5.6 kg

ELECTRICAL DATA

Voltage	1/N/PE~230 V	Insulation class	F
Power line	10m H05RN-F	Plug	Safety
Type of enclosure	IP 68	Rotation speed	2850 rpm

DPC

Type	Code No.	Motor rating P1	Current	Mechanical seal
DPC 150/7	N1080130	0.33 kW	1.4 A	Double lip seal lubricated in oil chamber with ceramic coating bushing shaft
DPC 200/10	N1080110	0.65 kW	2.9 A	Double seals lubricated by oil. Primary seal: carbon graphite/ceramic mechanical seal, Secondary seal: lip seal

DPC

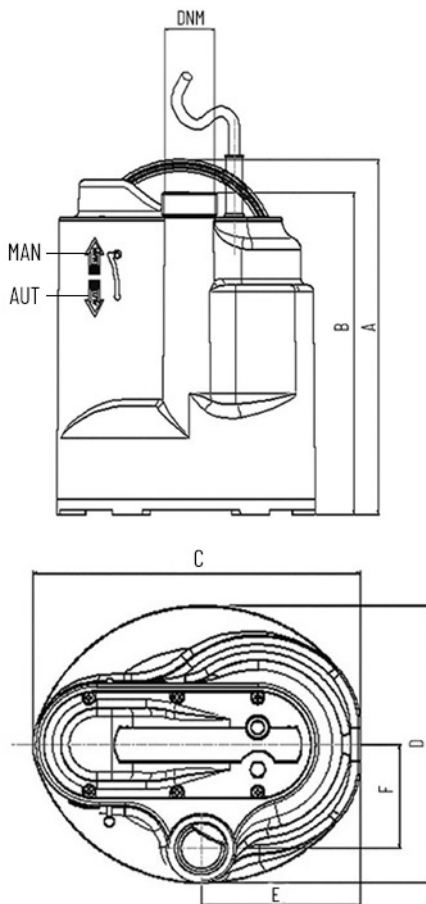

DPC

DRENA-LINE - CLEAN WATER

DIMENSIONS [mm]

Type	A	B	C	D	F	DNM	E
DPC 150/7	273	148	200	170	63	1 1/4"	97
DPC 200/10	273	148	200	170	63	1 1/4"	97

DPC

DRENA-LINE - CLEAN WATER