

WCFIX 260

SEWAGE LIFTING STATION FOR WASTEWATER CONTAINING FAECES

- Quiet
- Ready to connect
- Maintenance friendly
- Protection against overflow
- Active carbon filter
- Vortex impeller



DESCRIPTION

With the WCfix 260 it is possible to install an additional WC or an additional bathroom almost anywhere within the context of renovation or conversion works. When installed below the backup level, the device also provides anti-flooding protection.

The compact design of this pumping system for restricted use allows the direct connection of a standing toilet with a minimum flush volume of 6 l.

The pumping is carried out particularly quietly by the flow-optimized open centrifugal impeller. Due to this design, regular cleaning is not necessary and servicing works are significantly reduced.

Due to the restricted use, the installation is only permitted if the number of users is small and an additional WC above the backup level is available to them. A washbasin, a shower and a bidet can also be connected in the same room. According to EN 12050 part 3, further drainage facilities such as washing machines or bath-tubs may not be connected. We recommend the additional connection of a Hebefix sump. For entire apartments a compli pumping system should be used.

The appliance is fully pre-assembled, ready for connection and operate fully automatically as soon as the flush is actuated. When installed in bath and shower rooms, the applicable electrical regulations must be observed.

PERFORMANCE

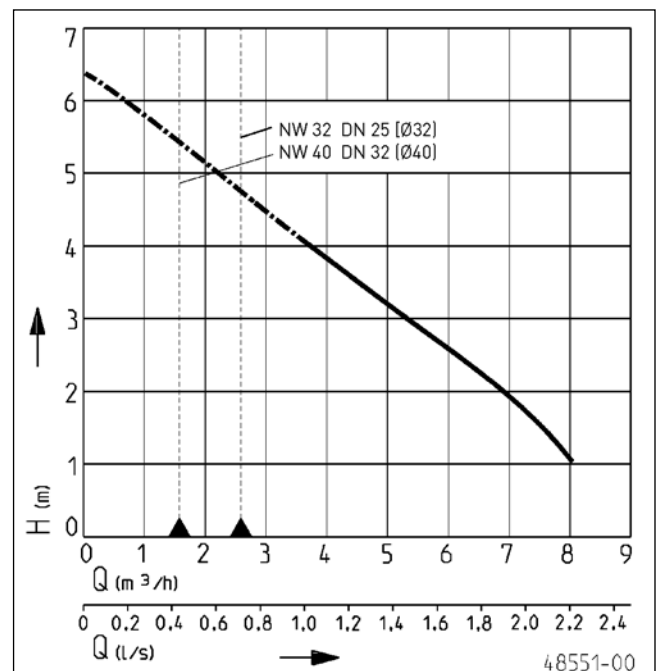

Type	Delivery head H [m]	1	2	3	3.5	4
WCfix 260	Flow rate Q [l/min]	133	111	87	75	61



WCFIX 260

SEWAGE LIFTING STATION FOR WASTEWATER CONTAINING FAECES

SCOPE OF SUPPLY

Device complies with EN 12050, ready to connect with cable and plug, built-in vent valve, complete with inlet plug-in seal,

discharge elbow, swing-type check valve 1¼", active carbon filter, clips and fixing material.

MECHANICAL DATA

Oil chamber	Yes	Motor housing	Stainless steel
Shaft	Stainless steel	Pump housing	GRP
Impeller	Vortex impeller, GFK	Weight	6 kg

ELECTRICAL DATA

Voltage	1/N/PE~230 V	Power line	1,5m H05VV-F
Motor rating P1	0.4 kW	Wires	3G1,5
Motor rating P2	0.25 kW	Type of enclosure	IP 24
Current	1.75 A	Plug	Safety

WCFIX 260

Type	Code No.
WCfix 260	JP09268

Dimensions WCfix 260 (mm)

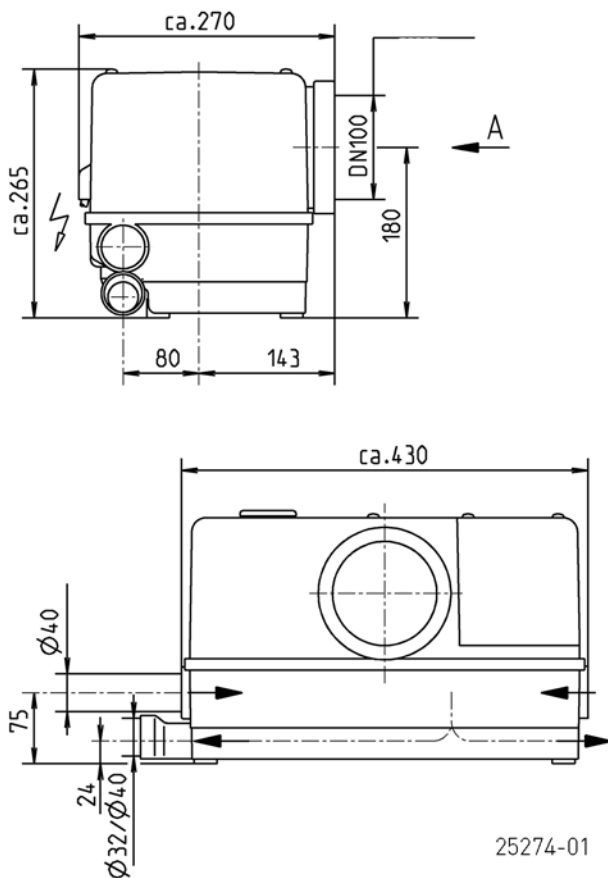

Performance

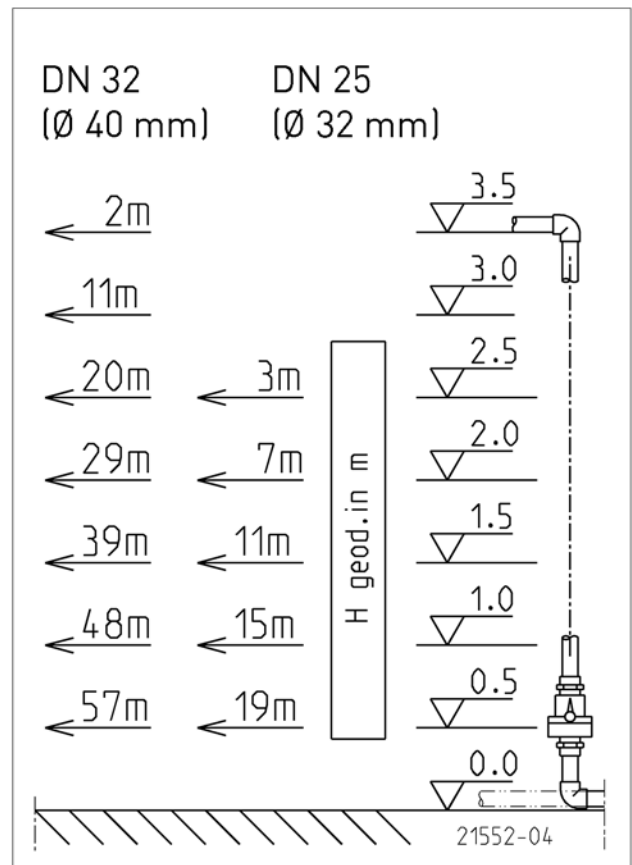

WCFIX 260

SEWAGE LIFTING STATION FOR WASTEWATER CONTAINING FAECES

Example of installation

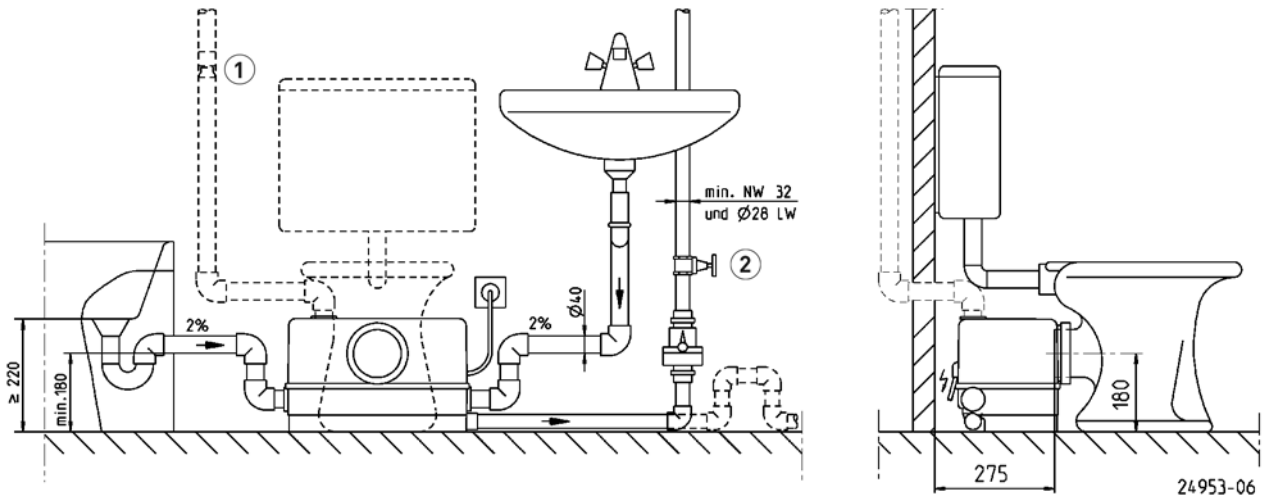

MECHANICAL ACCESSORY

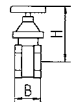
			Code No.
	① Special ventilation	special filter with housing, not for hot water	JP27484
	② Stop valve	1/4" (DN 32), PN 16 110x60 (HxB)	JP44785

WCFIX 260

SEWAGE LIFTING STATION FOR WASTEWATER CONTAINING FAECES