

COMPLI 400

SEWAGE LIFTING STATIONS

- Ready-to-connect
- Submersible
- Vertical/horizontal additional inlets
- Revolver clamping flange
- PE-tank approx. 70 L
- Vortex impeller
- Smart Home capable



DESCRIPTION

This sewage lifting station for detached houses is fitted for versatile fields of application. During the design work, special attention was given to easy handling (recessed grips), space-saving erection and uncomplicated installation.

The submersible unit is permitted for general use in areas subject to flooding. The control unit has to be fitted in a well ventilated flood-proof room.

The PE tank has freely accessible connections, a top-mounted cleaning opening and a height-adjustable inlet socket which can be infinitely adjusted on site to an inlet height of between 180 and 250 mm depending on the drainage situation.

Other horizontally and vertically arranged additional inlets increase the connection and drainage options. The vortex impeller of the pump offers the safety you can rely on.

The compli sewage lifting station can be integrated into a smart infrastructure. The FTJP radio transmitter is connected to the potential-free contact of the lifting station. It is now possible to transmit the switching status (e.g. an alarm message) to an EnOcean-capable smart home gateway (Wibutler, Afriso, Homee).

PERFORMANCE

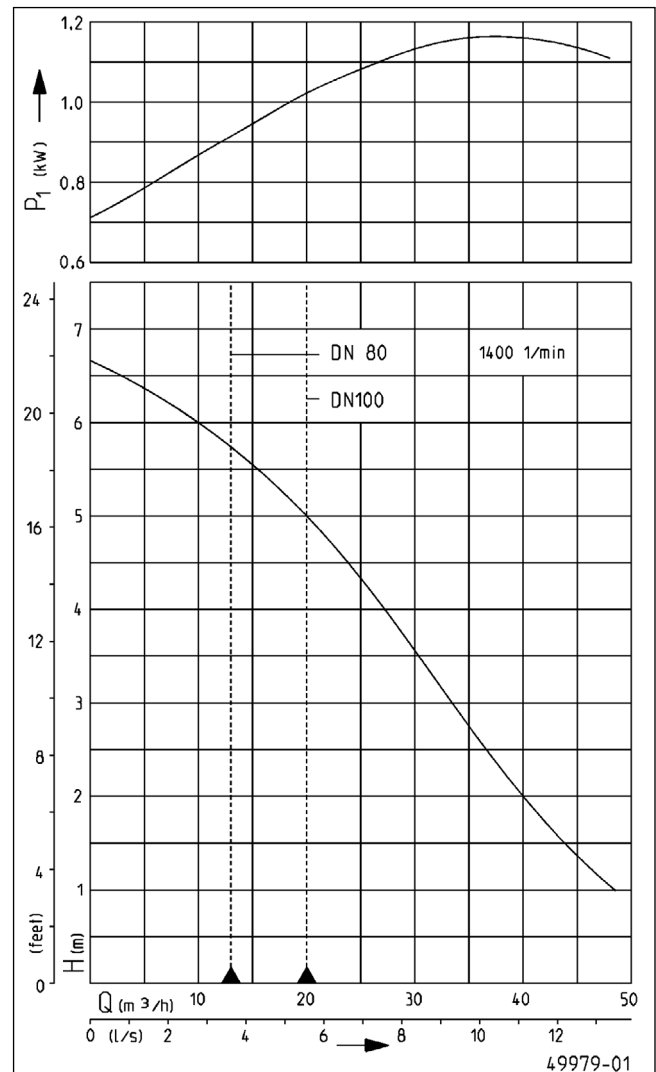

Type	Delivery head H [m]	1	2	3	4	5	6
complli 400	Flow rate Q [m³/h]	48	40	33	27	20	10

We reserve the right to change specifications without notice. Pump performance is subject to ISO 9906 tolerances

The minimum flow velocity in the pressure piping must be 0.7 m/s according to EN 12056. This data is represented in the performance curve as a limit of application.



COMPLI 400

SEWAGE LIFTING STATIONS

SCOPE OF SUPPLY

Ready-to-connect disposal system according to German / European standard 12050 with height-adjustable DN 100 inlet socket for inlet heights 180 to 250 mm, horizontal and vertical additional inlets Ø DN 100/DN 50, mounted submersible pump and DN 80 connection flange with pipe unit Ø 110, reducer ring Ø 110 to Ø 90, optionally with pre-mounted DN 80 non-return valve, one elastic connection each with clamps for plastic pressure pipes and a sleeved pipe for DN 70 ventilation pipe, automatic

level control, control unit (IP 44 type of protection) with motor protection, contactors, transformer, mains-dependent, optionally acknowledgeable alarm system and potential noc-contact for collective failure messages, optical display of sense of rotation (three-phase current), manual-0-automatic switch as well as an adjustable maintenance interval display.

Cable between tank and control 4 m. Cable between control and plug 1,5 m.

MECHANICAL DATA

Pump	Vertical single-stage	Impeller	Vortex impeller, GFK
Free passage	70 mm	Motor housing	Grey cast iron
Pressure pipe	DN 80/100	Pump housing	Plastic, grey cast iron
Bearing	Ball bearings, grease-lubricated	Submersible	Yes
Shaft	Stainless steel	Pressure outlet	DN 80
		Tank capacity	70 l

ELECTRICAL DATA

Power line	4m H07RN-F	Insulation class	F
Type of enclosure	IP 68	Winding thermostat	Yes

COMPLI 400

Type	Code No.	Voltage	Motor rating		Current	Wires	Plug	Weight
			P1	P2				
compl 400	JP50079	3/N/PE~400 V	1.25 kW	0.87 kW	2.2 A	6G1,5	CEE	52 kg
compl 400 E	JP50081	1/N/PE~230 V	1.55 kW	1.10 kW	7.1 A	4G1,5	Safety	53 kg
compl 400 with non-return valve mounted	JP50080	3/N/PE~400 V	1.25 kW	0.87 kW	2.2 A	6G1,5	CEE	67 kg
compl 400 E with non-return valve mounted	JP50082	1/N/PE~230 V	1.55 kW	1.10 kW	7.1 A	4G1,5	Safety	68 kg

COMPLI 400

SEWAGE LIFTING STATIONS

Dimensions with swing-type check valve

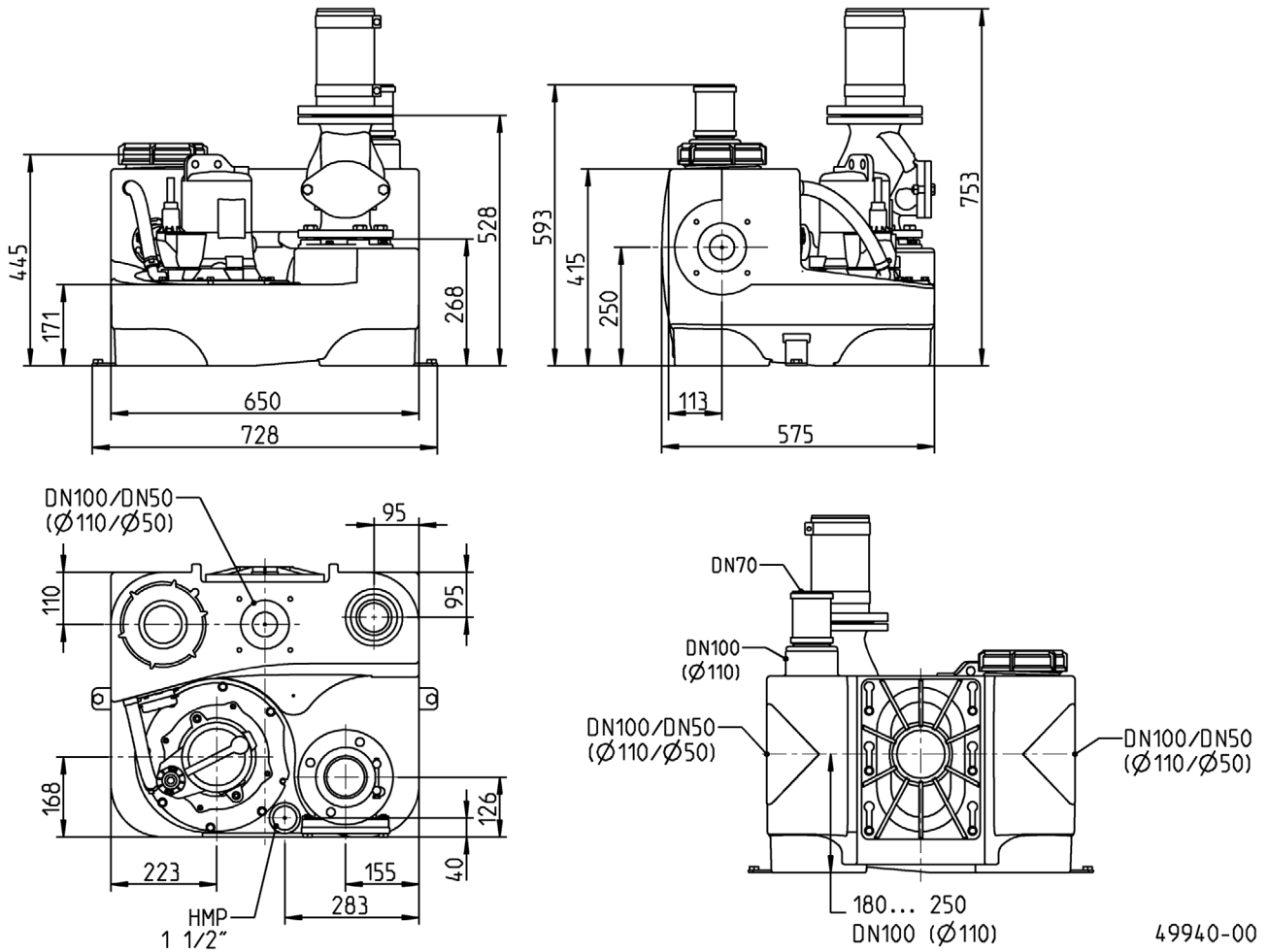

Example of installation

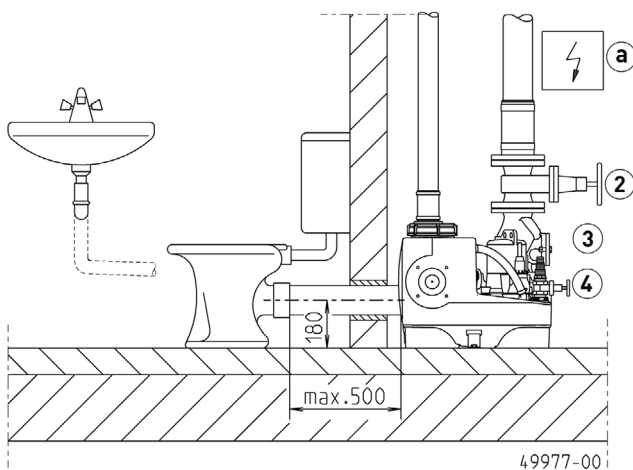

Example of installation

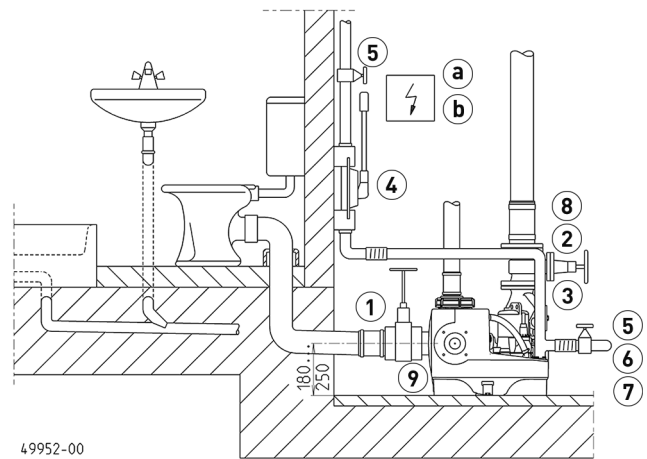







All types have DN 80 / PN 10 connecting flange, however with pipe socket DN 100. For this reason, a non-return valve for the pressure pipe need to be chosen for DN 80 only in case of direct erection. The ownstream pressure pipe is connected to DN 100 by an elastic connection. Sewage lifting stations are to be used for the transport of faecal matter and domestic wastewater in building drainage systems as described in German standard DIN 1986 T3. In keeping with the stipulations of German / European standard EN 12056-4 they

have to be mounted with collecting tanks inside building permitting a free space of 60 cm for operation and repair. The pressure pipe has to be passed above the locally defined backpressure level and a non-return valve tested in keeping with German / European standard 12050-4 has to be mounted. In keeping with German / European standard 12056 the ventilation pipe has to be passed up to the roof. EN 12056 paragraph 5.1 In applications where the waste-water inlet must not be interrupted a double system has to be installed.



COMPLI 400

SEWAGE LIFTING STATIONS

MECHANICAL ACCESSORY

				Code No.
	① Inlet gate valve PVC	with two pipe sockets, DN 100, PN1	360x295 (HxW)	JP28297
	② Sluice valve	DN 80, PN 10, EN 1171	315x180 (HxB)	JP00639
	③ Swing-type check valve	R 80 EN 12050-4	DN 80, PN 4, flange PN 10, EN 558, 260 (H)	JP00706
		R 80 G EN 12050-4	DN 80, PN 4, flange PN 10, EN 558, with counter weight, 260 (H)	JP00707
	Ball-type check valve	K 80 EN 12050-4	DN 80, PN 4, flange PN 10, EN 558, 260 (H)	JP49205
	④ Connection for emergency de-watering	with stop valve and hose connection 1", 1/4" and 1/2"		JP49138
	Hand diaphragm pump	for emergency purposes (up to H geod 15 m)	640x1 1/2" (HxD)	JP00255
	⑤ Stop valve	brass, 1/2" (DN 40), PN 16	125x60 (HxB)	JP44786
	⑥ Elastic connection	1/2" (DN 40), PN 4	120x50 (HxD)	JP44777
	⑦ Hose band clamp	1/2"		JP44763
	⑧ Adapter ring	DN 100-DN 80 SML		JP50174
	⑨ Opening set	DN 100, required for lateral connection		JP50172

ELECTRICAL ACCESSORY

				Code No.
	① Rechargeable battery	for mains independent alarm		JP44850
	② Smart Home	FTJP radio transmitter		JP47209
	③ Alarm unit	Alarm unit compli	contact switch, 4 m cable	JP50171